



# Deep Cycle Long Life series

Datasheet : NTD12-40(12V40AH)

<b>Nominal Voltage</b>	12V
<b>Number of cell</b>	6
<b>Design Life</b>	12 years
<b>Nominal Capacity 77°F(25°C)</b>	
20 hour rate (2.00A, 10.5V)	40.0Ah
10 hour rate (3.66A, 10.5V)	36.6Ah
5 hour rate (6.7A, 10.5V)	33.5Ah
1 hour rate (25.3A, 9.6V)	25.3Ah
<b>Internal Resistance</b>	
Fully Charged battery 77°F(25°C)	≤9.5mOhms
<b>Self-Discharge</b>	
3% of capacity declined per month at 20°C(average)	
<b>Operating Temperature Range</b>	
Discharge	-20~60°C
Charge	-10~60°C
Storage	-20~60°C
<b>Max. Discharge Current 77°F(25°C)</b>	400(5s)
<b>Short Circuit Current</b>	900A
<b>Charge Methods:</b> Constant Voltage Charge 77°F(25°C)	
<b>Cycle use</b>	2.40-2.45VPC
<b>Maximum charging current</b>	13.5A
<b>Temperature compensation</b>	-30mV/°C
<b>Standby use</b>	13.6-13.8V
<b>Temperature compensation</b>	-20mV/°C



Wide Range Temperature	Warranty	Maintenance Free
Deep cycle Technology	easy use	long life

## Mechanical Characteristics

Length(mm / inch)	197.5 / 7.72
Width(mm / inch)	165.5/ 6.54
Height(mm / inch)	170 / 7.17
Total Height(mm / inch)	170 / 7.17
Approx. Weight(Kg / lbs)	12.4/ 27.28

\* Weight deviation: ± 5%

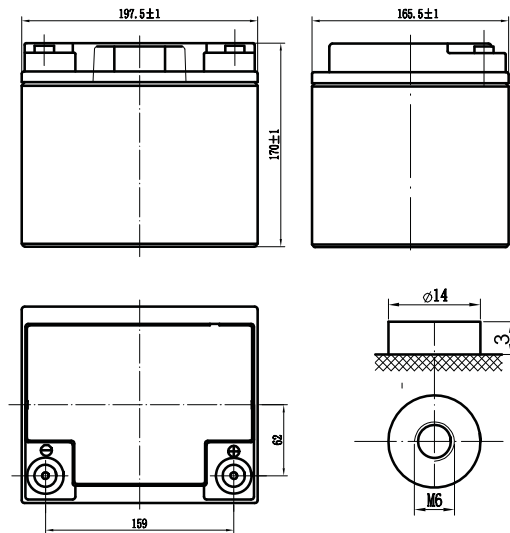

## Technical Characteristics

### Discharge Constant Current (Amperes at 77°F25°C)

End Point	10min	15min	30min	1h	3h	5h	10h	20h
1.60V	89.4	71.2	41.0	25.5	10.6	7.32	4.14	2.08
1.65V	85.0	66.9	39.7	25.2	10.3	7.20	4.08	2.06
1.70V	80.5	64.8	38.0	24.8	10.1	7.07	4.02	2.04
1.75V	76.1	63.0	37.1	24.5	9.85	6.97	3.95	2.02
1.80V	69.1	57.0	35.4	23.4	9.62	6.77	3.88	2.00

### Discharge Constant Power (Watts at 77°F25°C)

End Point	10min	15min	30min	45min	1h	2h	3h	5h
1.60V	170	137	90.6	68.6	54.8	30.8	22.8	14.9
1.65V	157	124	80.9	62.5	50.4	28.7	21.5	14.0
1.70V	149	120	78.3	59.3	49.6	27.9	20.7	13.8
1.75V	142	117	75.8	58.1	48.8	27.4	20.4	13.6
1.80V	135	113	73.2	56.9	47.9	26.9	20.0	13.5

(Note)The above characteristics data are average values obtained within three charge/discharge cycles. All data shall be changed without notice, Neata reserves the right to explain and update the information.

**SHENZHEN OFFICE (CHINA)**  
 Tel: +86-755-2691-9474  
 Fax: +86-755-2691-9474

Recognized under CE/IEC and certified by ISO9001 ,14001



# Neata<sup>®</sup> Deep Cycle Long Life series

## Datasheet : NTD12-40(12V40AH)

### Discharge Characteristics Curve

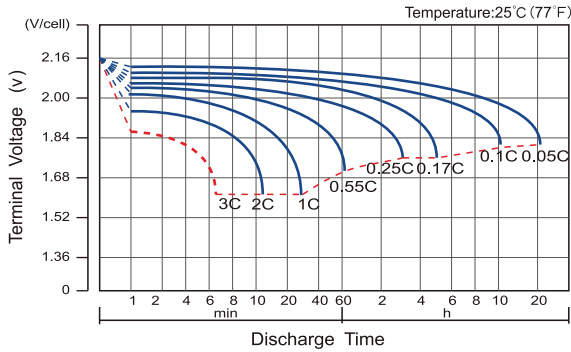

### Charge Characteristic Curve For Standby Use

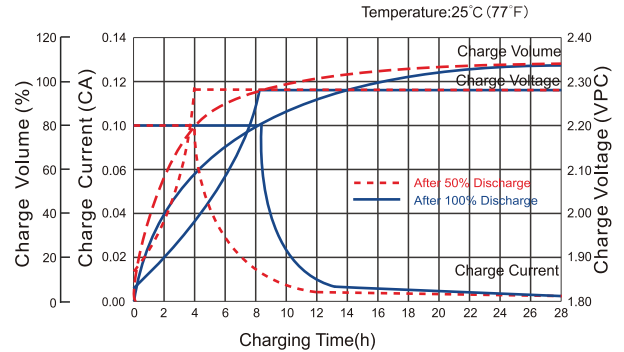

### Cycle Life In Relation To Depth Of Discharge

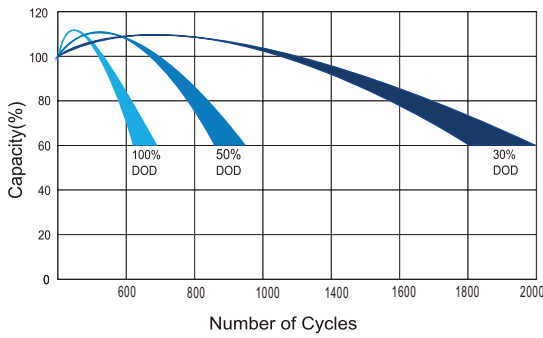

### Temperature Effects On Capacity

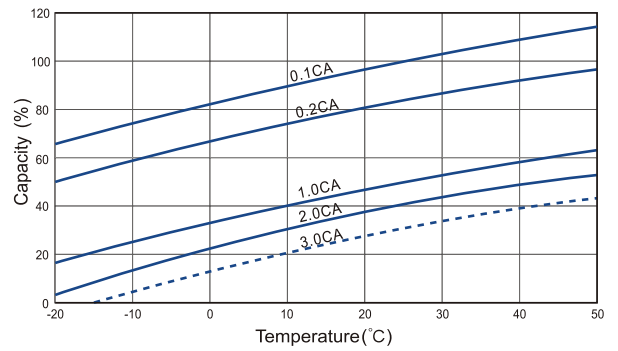

### Relationship Between Charging Voltage And Temperature

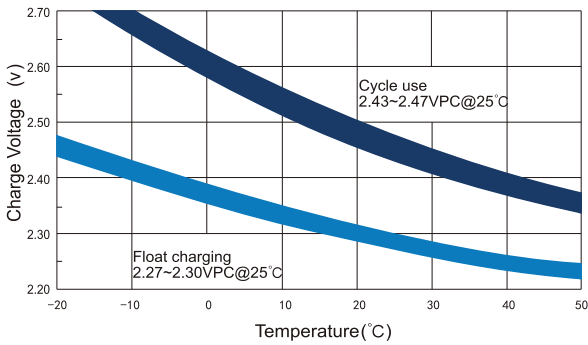

### Storage Characteristics

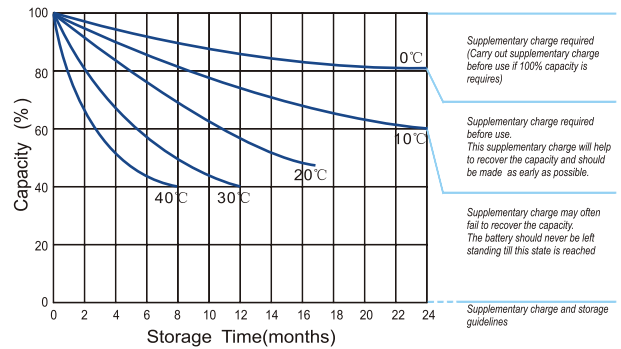

### Effect Of Temperature On Long Term Life

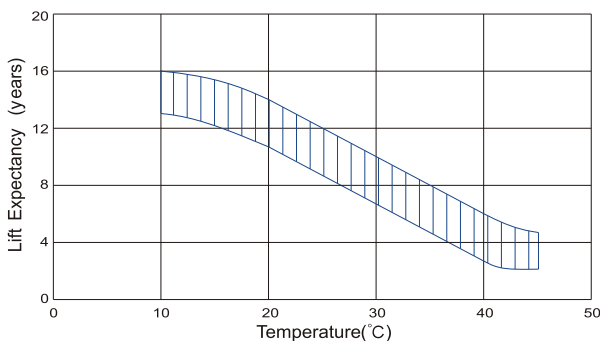

### Life Characteristics Of Standby Use

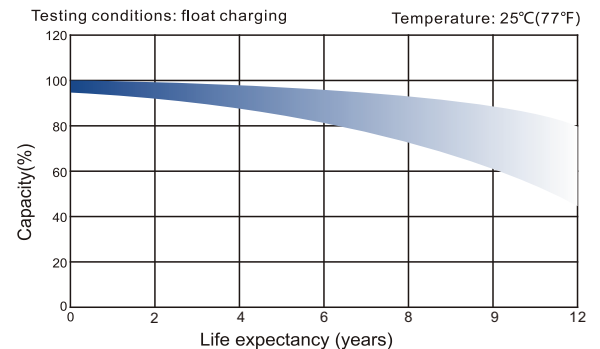

SHENZHEN OFFICE (CHINA)  
Tel: +86-755-2691-9474  
Fax: +86-755-2691-9474

Recognized under CE/IEC and certified by ISO9001,14001

